

Rev.	Date of issue	Description	Sign
0001	10/04/2026	First edition	T.M.

Monitor Dimension

**ACTIVE AREA
1655x932**

**Max. Monitor Dimension
1700x964**

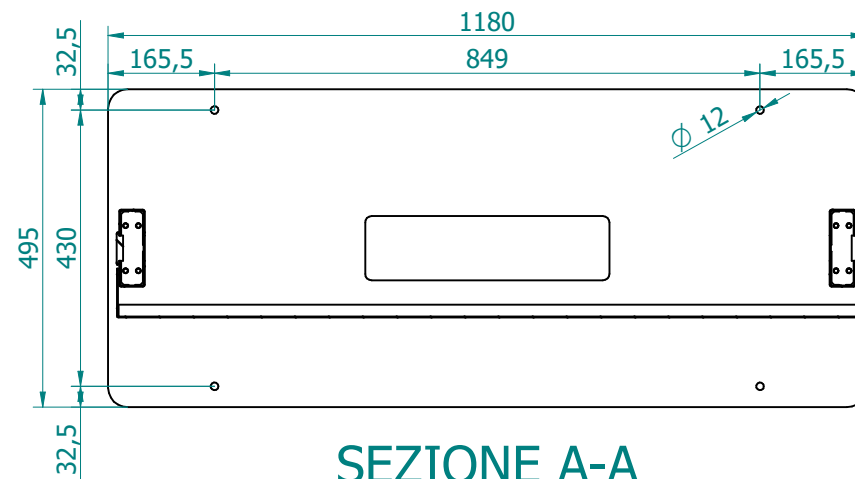
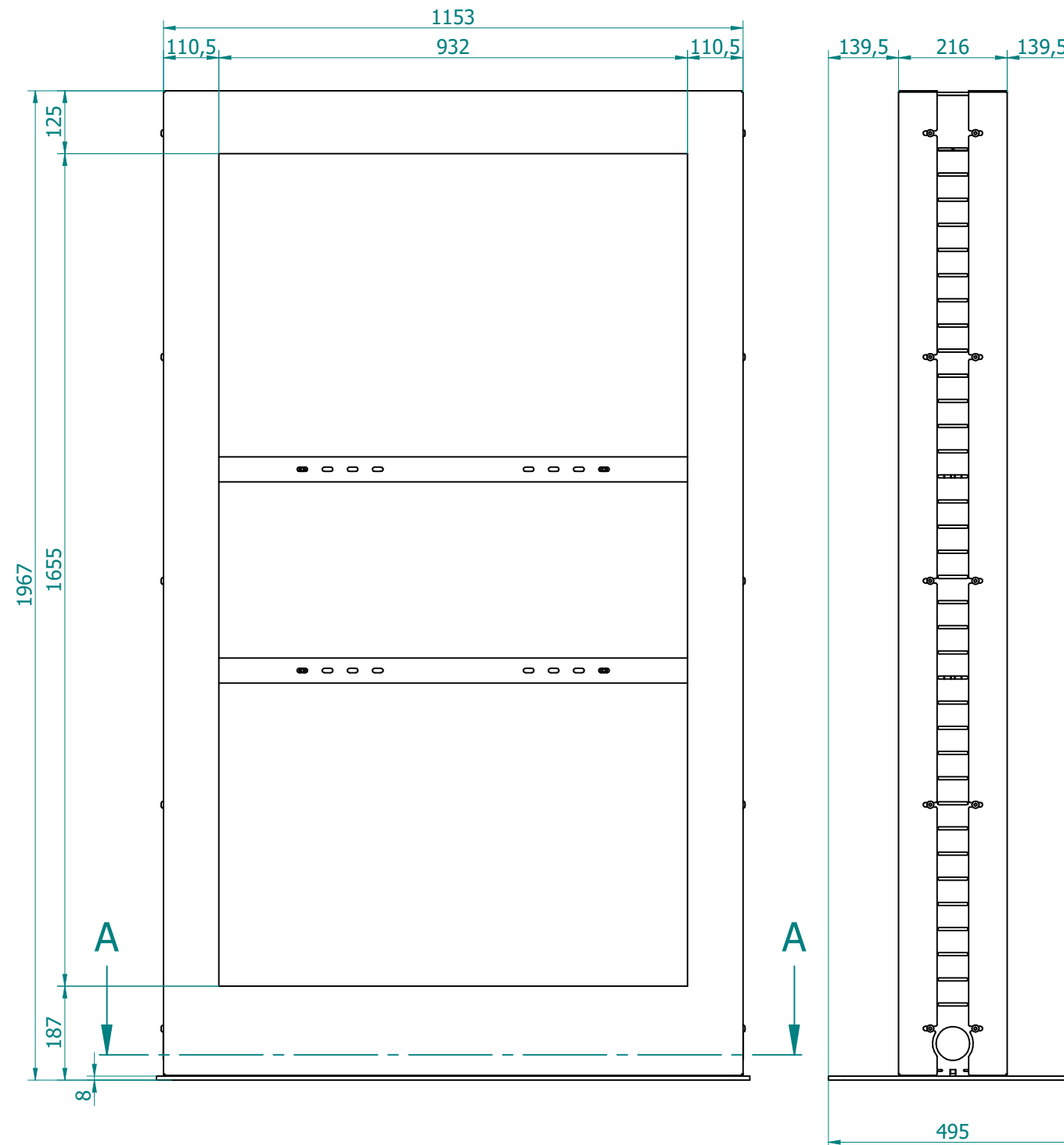

Weight 137 Kg.

Chamfers not indicated 0,5x45°	Roughness	General tolerances For linear dimensions: ± 0.1 mm For angular dimensions: ISO 2768-m	Weight [kg] 136.71 kg	Scale 1/1	
		Created by Trabucco Marco	Date of issue 10/04/2026		
Code name/File name 09293-75		Title/Supplementary title Totem 75" Double Face			
Proprieta' di O.M.B. SRL - Senza autorizzazione scritta della stessa il presente disegno non potra' essere utilizzato per la costruzione dell'oggetto rappresentato ne venire comunicato a terzi.					Sheet 1/2 Paper size A3

SEZIONE A-A

Rev.	Date of issue	Description	Sign
0001	10/04/2026	First edition	T.M.

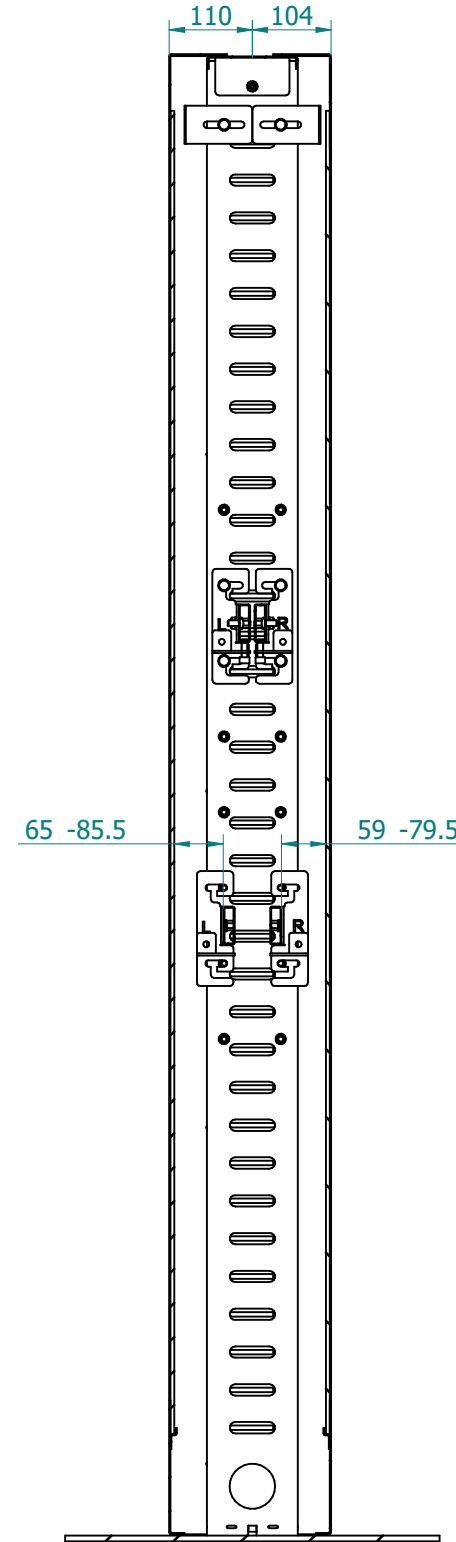
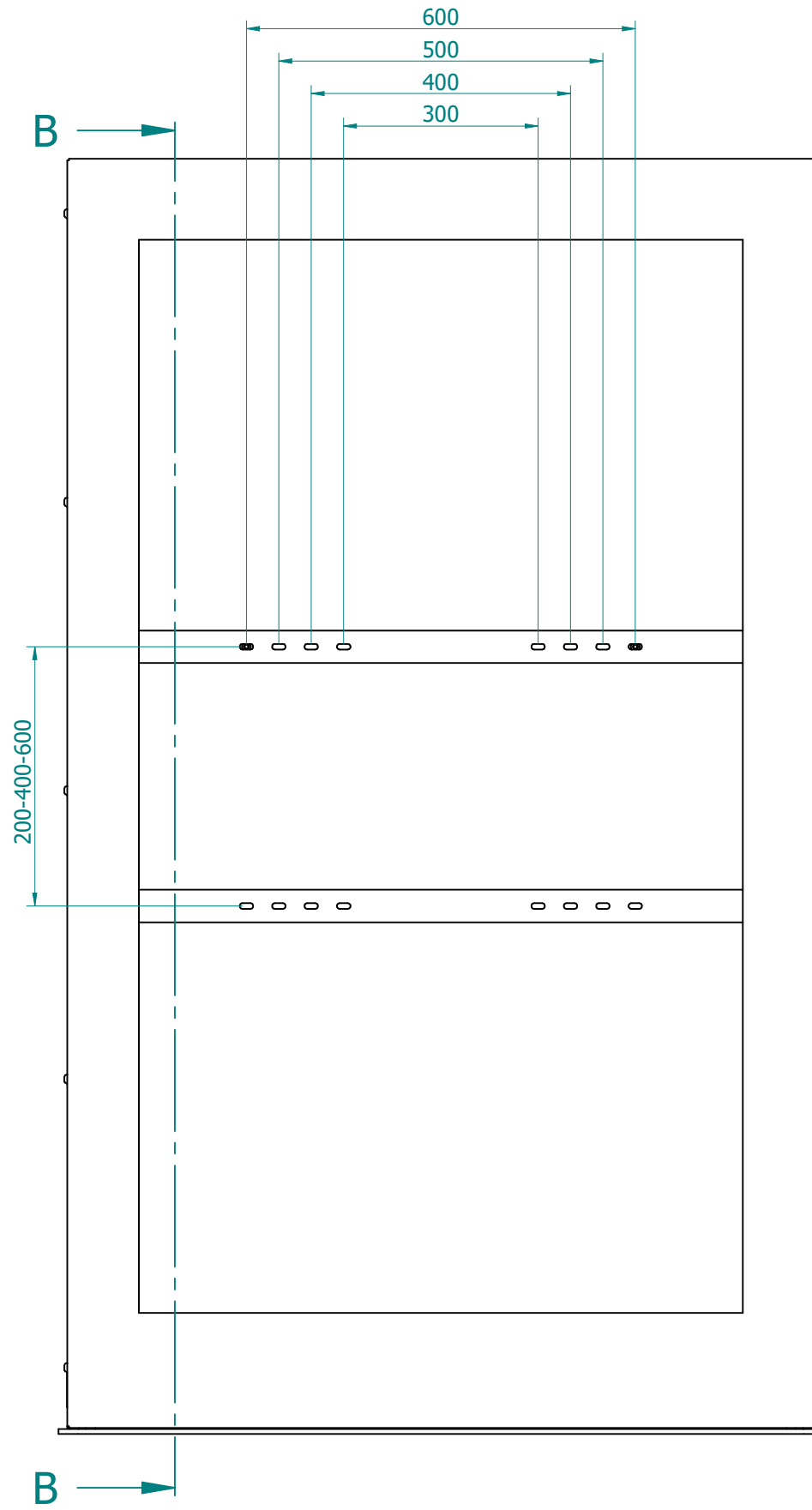

SEZIONE B-B

Chamfers not indicated 0,5x45°	Roughness	General tolerances For linear dimensions: ±0.1 mm For angular dimensions: ISO 2768-m	Weight [kg] 136.71 kg	Scale 1/1	
		Created by Trabucco Marco	Date of issue 10/04/2026		
		Title/Supplementary title Totem 75" Double Face			
Code name/File name 09293-75					Sheet 2\2
Proprietà di O.M.B. SRL - Senza autorizzazione scritta della stessa il presente disegno non potrà essere utilizzato per la costruzione dell'oggetto rappresentato né venire comunicato a terzi.					Paper size A3