

Rev.	Date of issue	Description	Sign
0001	10/04/2026	First edition	T.M.

Monitor Dimension

**ACTIVE AREA
945x533**

**Max. Monitor Dimension
1225x576**

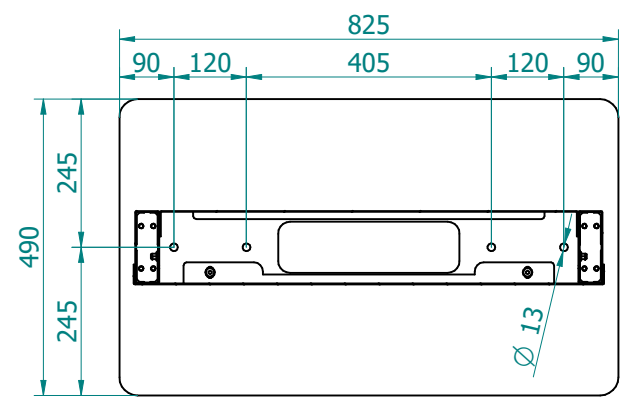
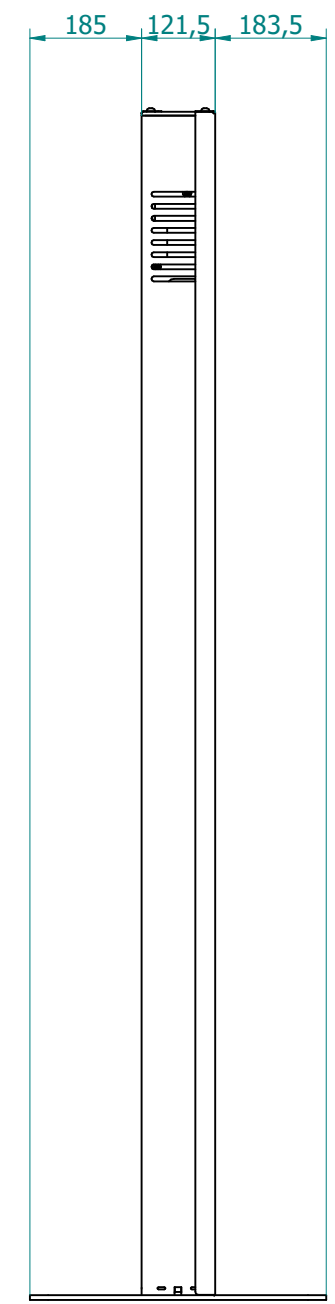
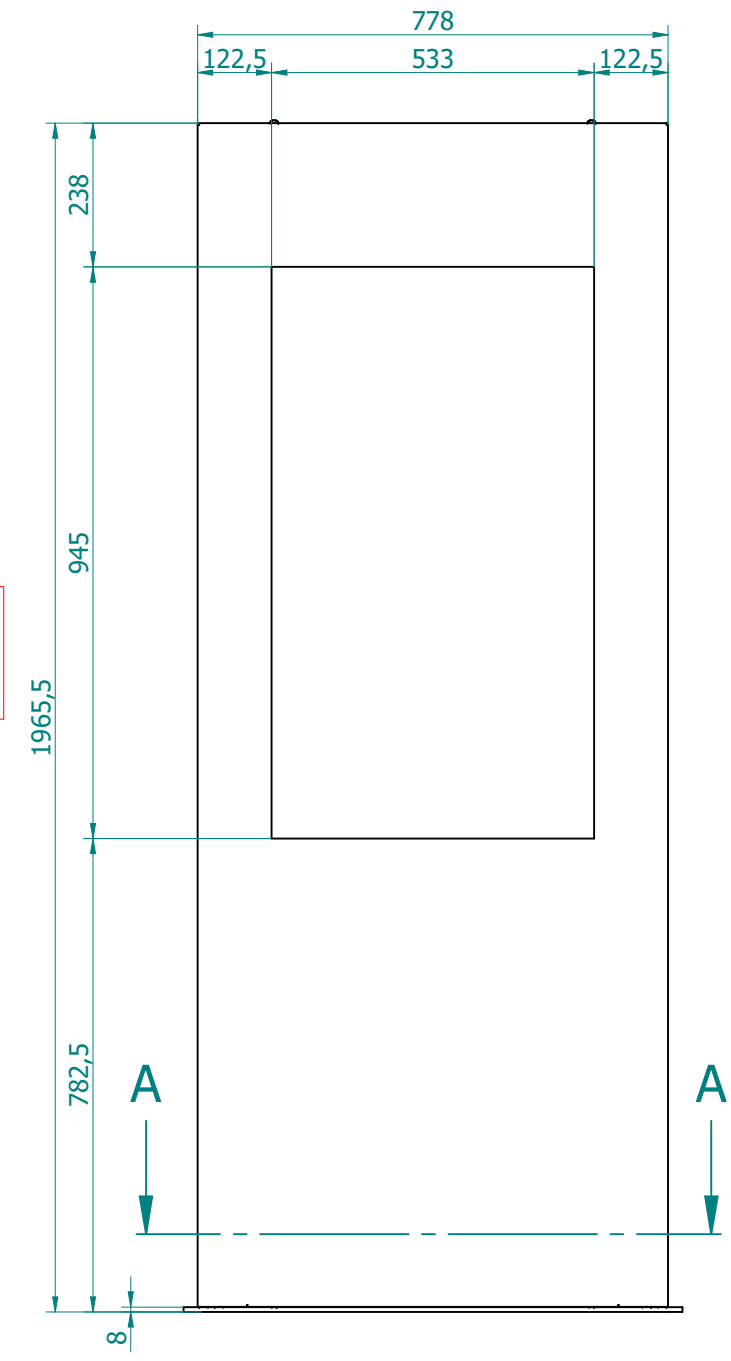

SEZIONE A-A

Weight 94 Kg.

Chamfers not indicated 0,5x45°	Roughness	General tolerances For linear dimensions: ±0.1 mm For angular dimensions: ISO 2768-m	Weight [kg] 93,25 kg	Scale 1/1	
		Created by Trabucco Marco	Date of issue 10/04/2026		
Code name/File name 09266-STD-43		Title/Supplementary title DragonFly 43" STD		Sheet 1/2	Paper size A3
Proprietà di O.M.B. SRL - Senza autorizzazione scritta della stessa il presente disegno non potrà essere utilizzato per la costruzione dell'oggetto rappresentato né venire comunicato a terzi.					

Rev.	Date of issue	Description	Sign
0001	10/04/2026	First edition	T.M.

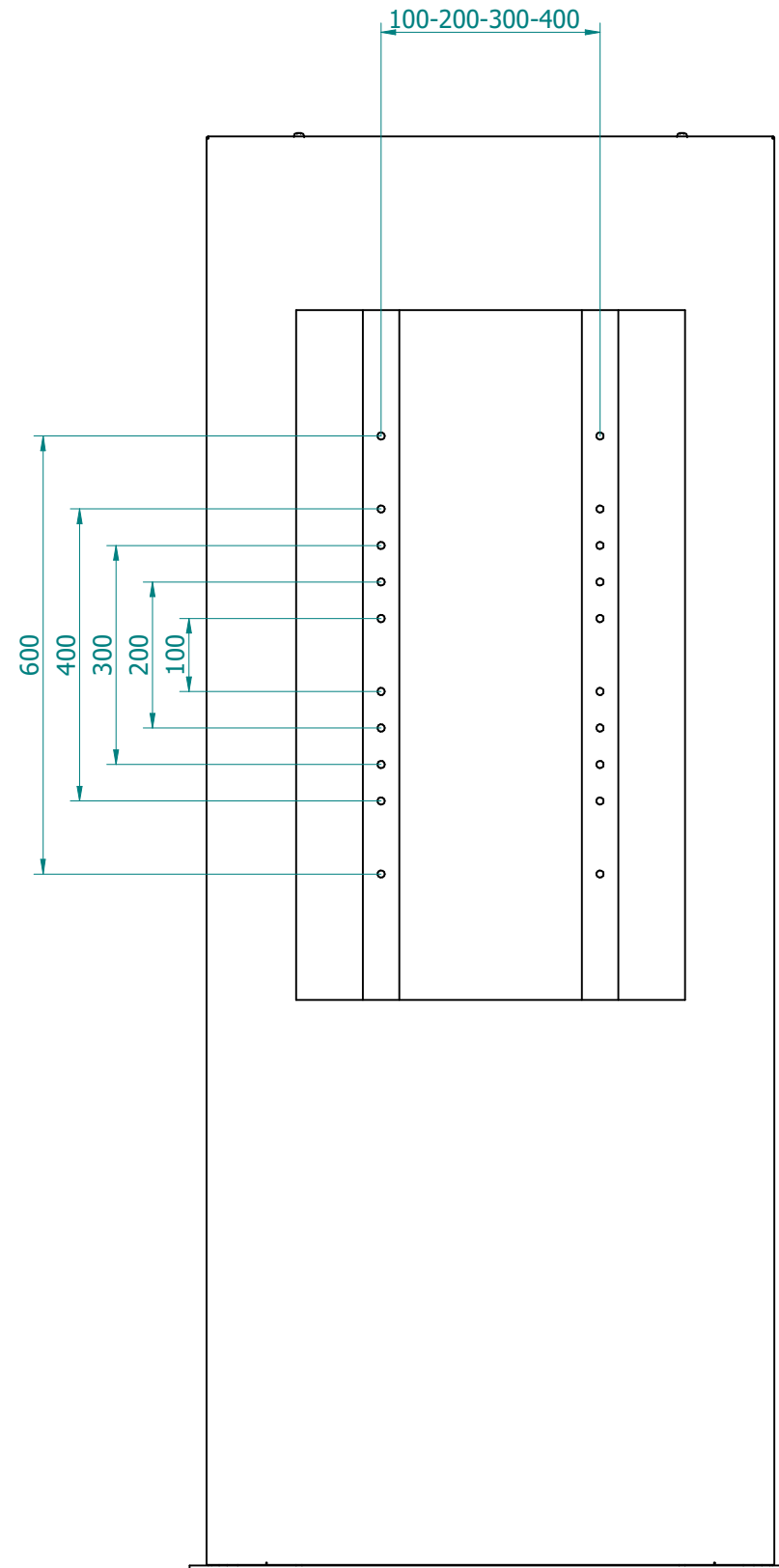

Chamfers not indicated 0,5x45°	Roughness	General tolerances For linear dimensions: ±0.1 mm For angular dimensions: ISO 2768-m	Weight [kg] 93,25 kg	Scale 1/1	
		Created by Trabucco Marco	Date of issue 10/04/2026		
		Title/Supplementary title DragonFly 43" STD			
Code name/File name 09266-STD-43					Sheet 2\2
Proprieta' di O.M.B. SRL - Senza autorizzazione scritta della stessa il presente disegno non potra' essere utilizzato per la costruzione dell'oggetto rappresentato ne venire comunicato a terzi.					Paper size A3