

dvLED MOTORIZED TROLLEY  
PROFESSIONAL DISPLAY SUPPORT

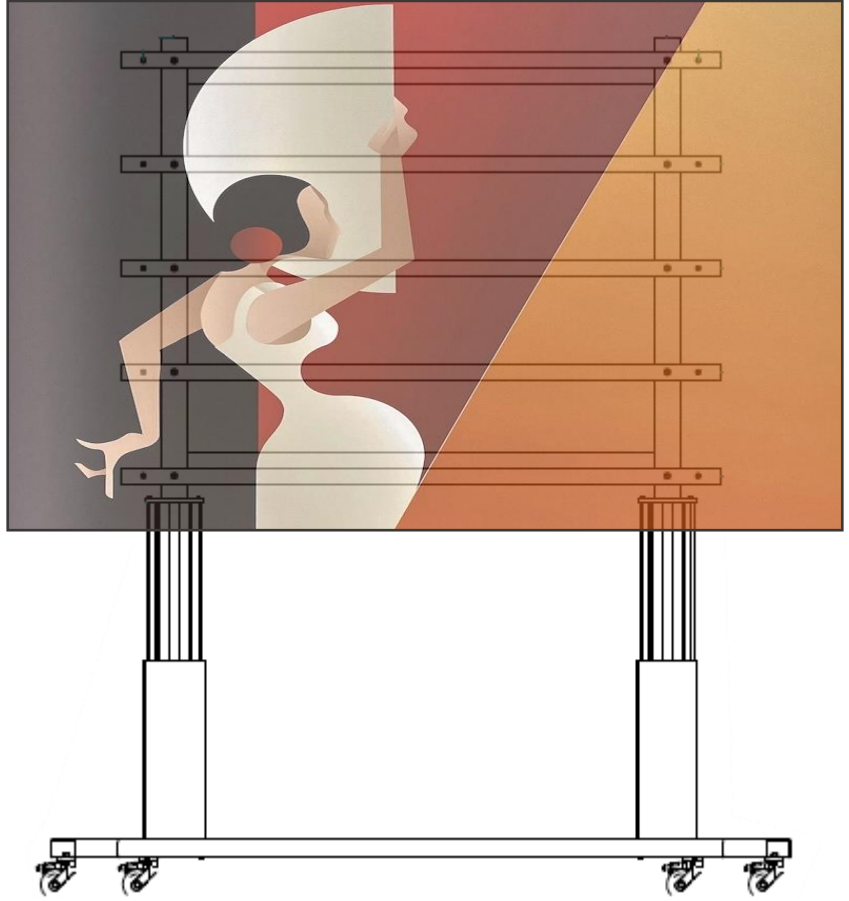

Each structure is designed based on the customer's needs and the size of the individual LED tile.

The structure is made of two gray motorized columns, the base and support of the LEDwall can be black or gray upon customer request.

There are two versions

- Version with double column with 500mm excursion to support LEDwall with a maximum weight of 250Kg – suitable for dvLED screen indicative dimension 90", 110" or 135".
- Version with double column with 660mm excursion to support LEDwall with a maximum weight of 500Kg – suitable for dvLED screen with indicative dimension 145", 165" or 220".

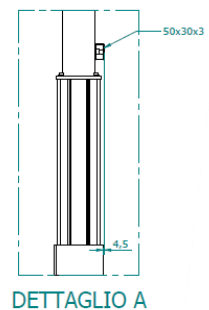
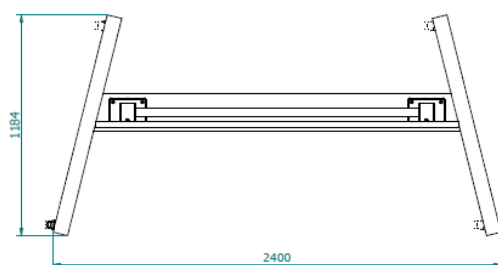
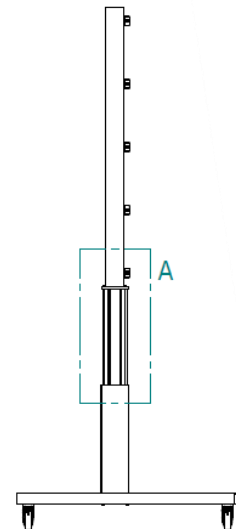
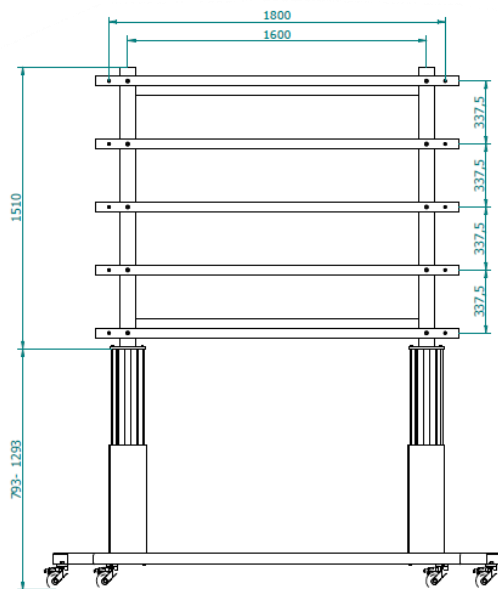



OMB srl | Via Risorgimento, 25 | 38070 STENICO (TN) | ITALY  
Tel. +39 0465 771036 | [omb@ombitaly.it](mailto:omb@ombitaly.it) | [www.ombitaly.it](http://www.ombitaly.it)