

dvLED OUTDOOR ENCLOSURE
PROFESSIONAL DISPLAY SUPPORT

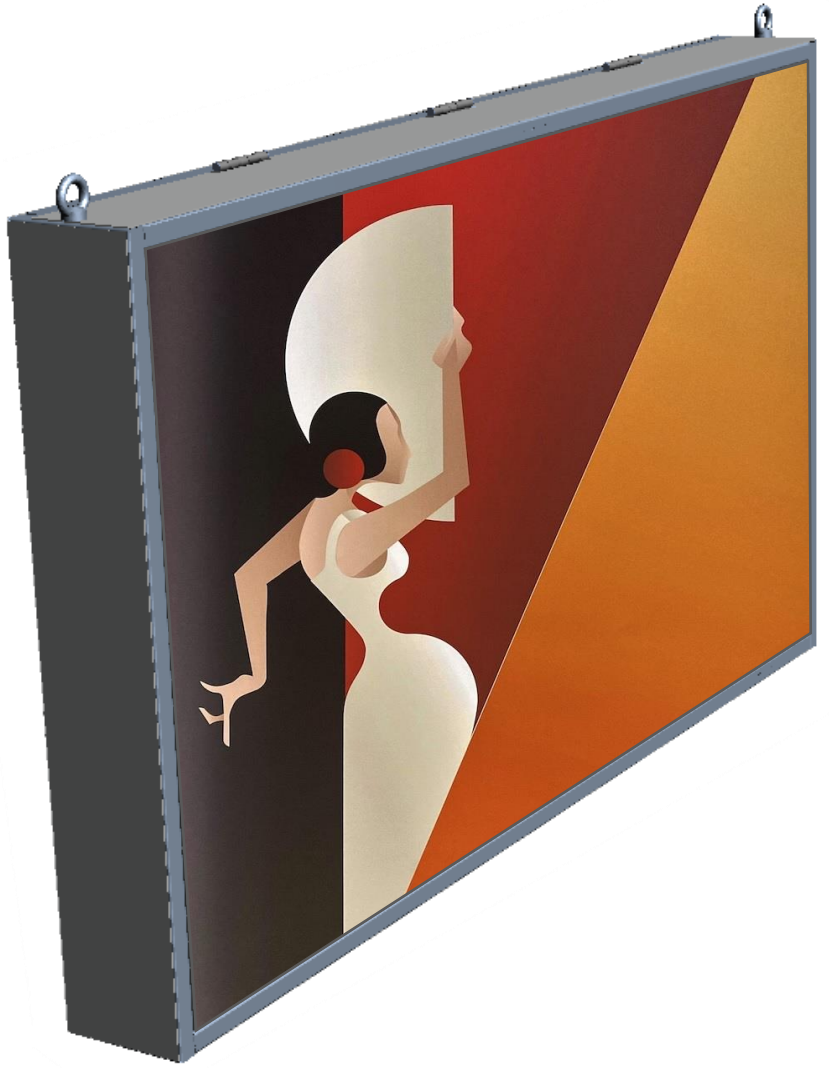

LED outdoor enclosures are usually installed in environments such as railway or marine stations, shopping centers or other places where it is necessary to have a large video surface and IP65 protection for all electrical components.

Each structure is designed based on the customer's needs and the size of the individual LED tile.

Depending on the need, access for maintenance can be from the front or the back. It can be equipped with an IP65 protected slot to house the electrical components

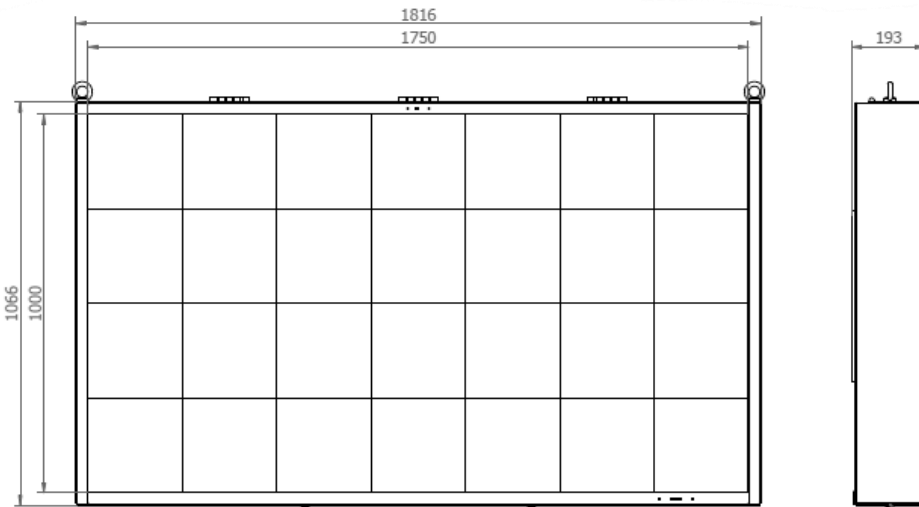
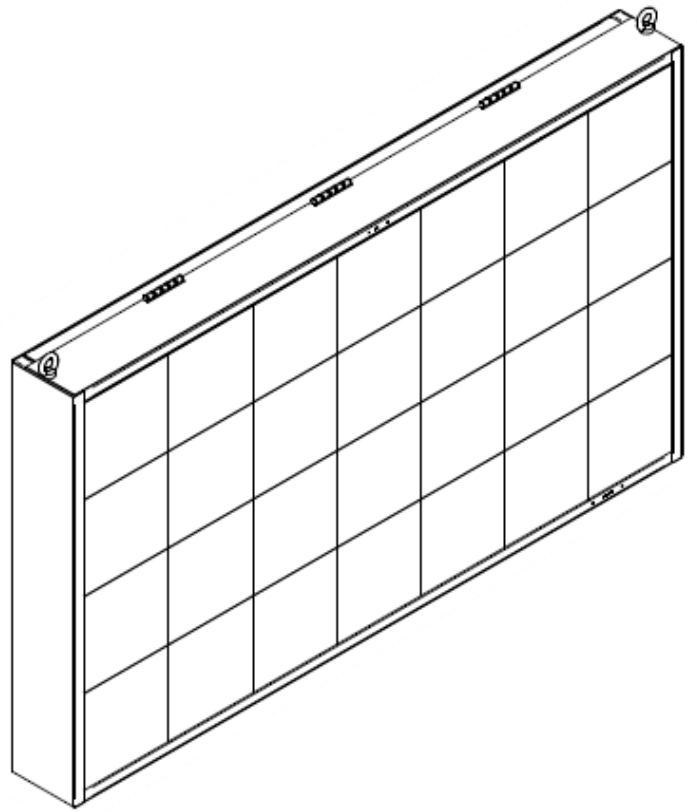

FRONT | SIDE VIEW

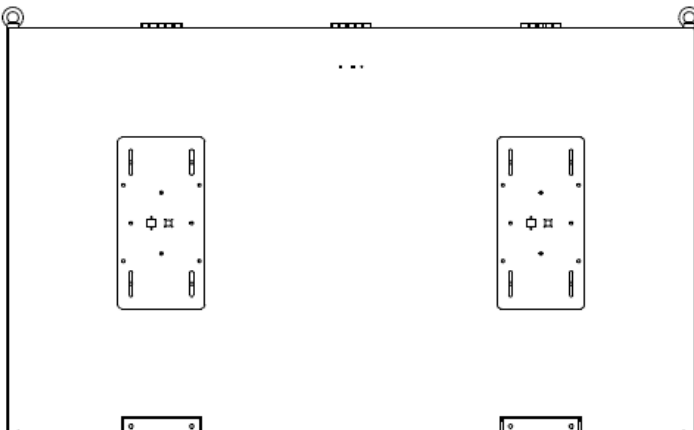

BACK VIEW

Example of production

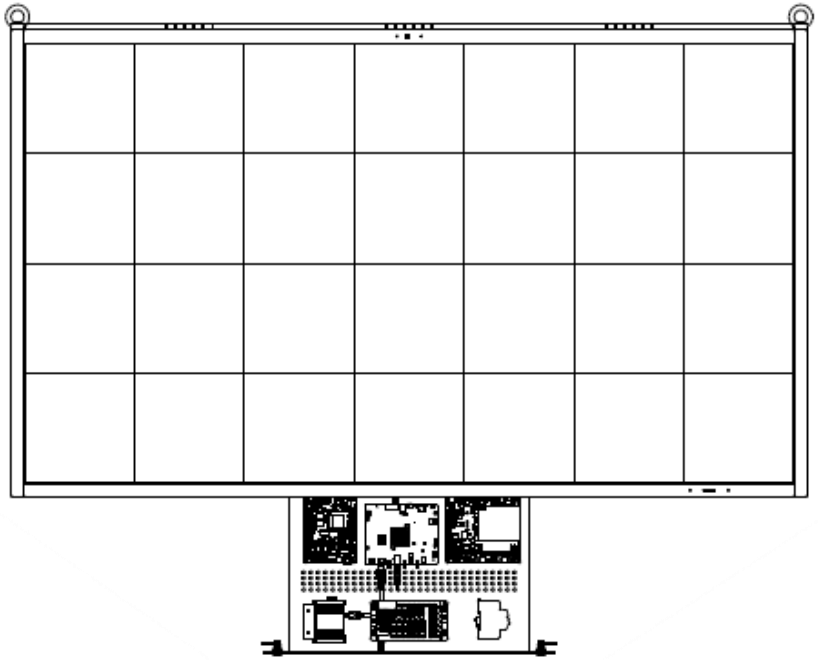
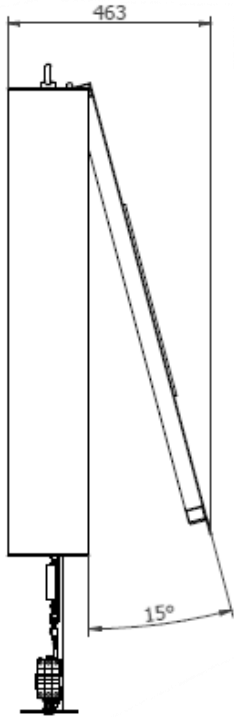

BACK OR FRONT ACCESS
FOR MAINTENANCE

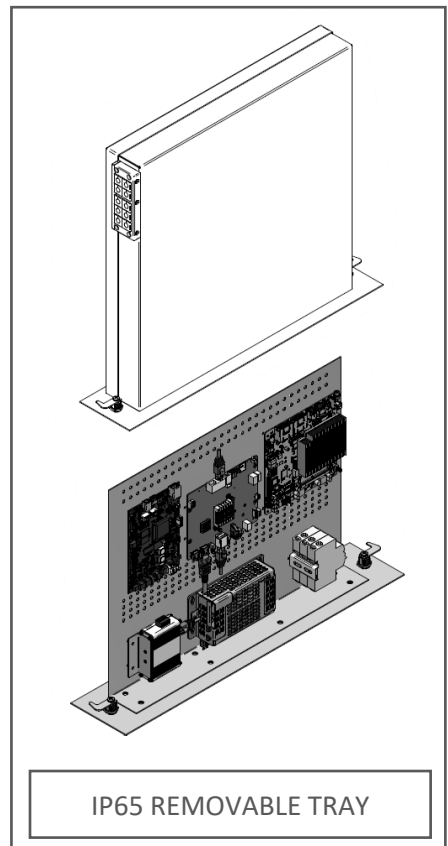
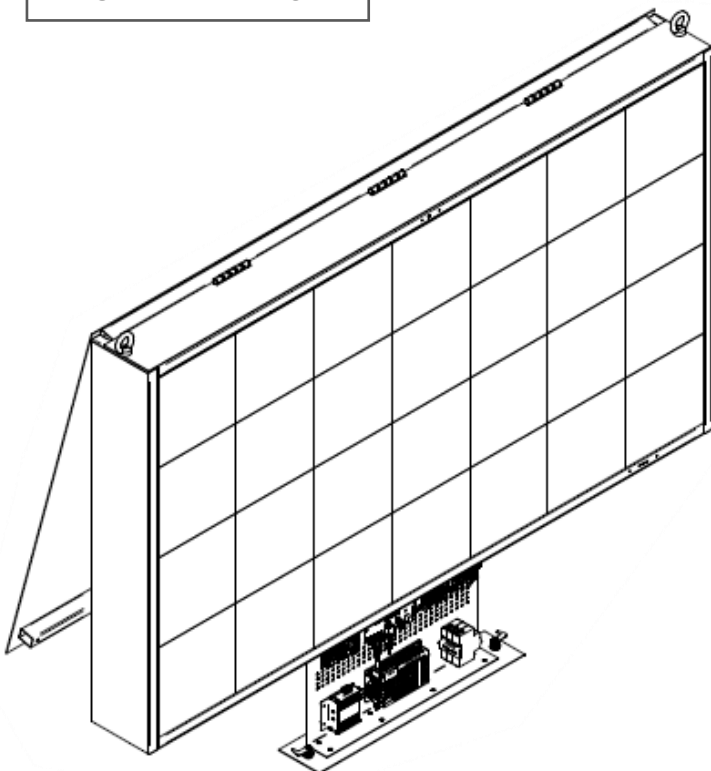



OMB srl | Via Risorgimento, 25 | 38070 STENICO (TN) | ITALY
Tel. +39 0465 771036 | omb@ombitaly.it | www.ombitaly.it